

4-Sheave Block 700 kg (1544 lbs.) 60-Ton Capacity
Single Sheave Block 400 kg (881 lbs.) 26-Ton Capacity
Ball 300 kg (661 lbs.) 9-Ton Capacity

GMK4100L-1

Product Guide

ASME B30.5 Imperial 85%



Features

- 100 t (115 USt) capacity
- 60 m (197 ft) seven-section main boom
- 11 m - 17.6 m (36 ft - 58 ft) swingaway extension
- 8 m (26 ft) boom extension
- Single-engine concept design
- Five-position outrigger settings: 0%, 40%, 60%, 80% and 100%

GROVE GMK4100L-1

Powerful Everywhere: With high capacities and industry-leading compact dimensions, the GMK4100L-1 allows you to secure more jobs than ever before.

Features

> Industry-leading compact dimensions

The minimum width of the GMK4100L-1 is 2,55 m (8.4 ft) and the overall length is 13,18 m (43.3 ft)

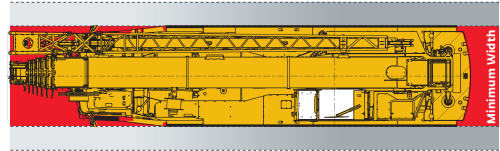

> Global counterweight configuration

Fully removable counterweight to reduce the basic crane's Gross Vehicle Weight to help meet diverse roading regulations. Counterweight can be transported on the rear of the carrier chassis, providing a low center of gravity.



> Single-engine concept

Equipped with a Mercedes-Benz Tier 4 final engine the GMK4100L-1 utilized a single-engine concept to keep fuel consumption to a minimum. Using the ECO mode, the GMK4100L-1 is the most fuel-efficient crane in its class.



> CraneSTAR is an exclusive and innovative crane asset management system

Helps improve your profitability and reduce costs by remotely monitoring critical crane data. Visit www.cranestar.com for more information.

Jobsite benefits

- > Access narrow jobsites and utilize a more compact radius to gain a better position for lift performance. The GMK4100L-1's compact size and five outrigger positions provides excellent job site flexibility unmatched in the market.
- > Human Machine Interface (HMI) allows for control of the MEGATRAK™ suspension system from both sides of the carrier allowing for adjustment of ground clearance independent of the outriggers. The GMK4100L-1 can also be equipped with an outrigger pad load indicator with visibility on both sides of the carrier or from the operators cab.
- > MEGATRAK™ independent suspension, all-wheel steering system and steer by wire technology provides increased ground clearance, adjustable suspension and reduces tire-wear to provide maximum maneuverability in all-terrains.

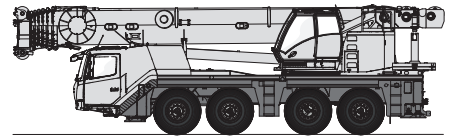

Manitowoc Crane Care when you need it.

The assurance of the world's most advanced crane service and support to get you back to work fast.



Manitowoc Finance helps you get right to work generating profits for your business.

Financial tools that help you capitalize on opportunity with solutions that fit your needs.

Contents

Dimensions	5
Counterweight	8
Data	9
Weights	10
Working range - Main boom	12
Load charts - Main boom	13
Working range - Main boom and telescopic swingaway	24
Load charts - Main boom and telescopic swingaway	25
Specifications	28
Symbols glossary	29

Dimensions

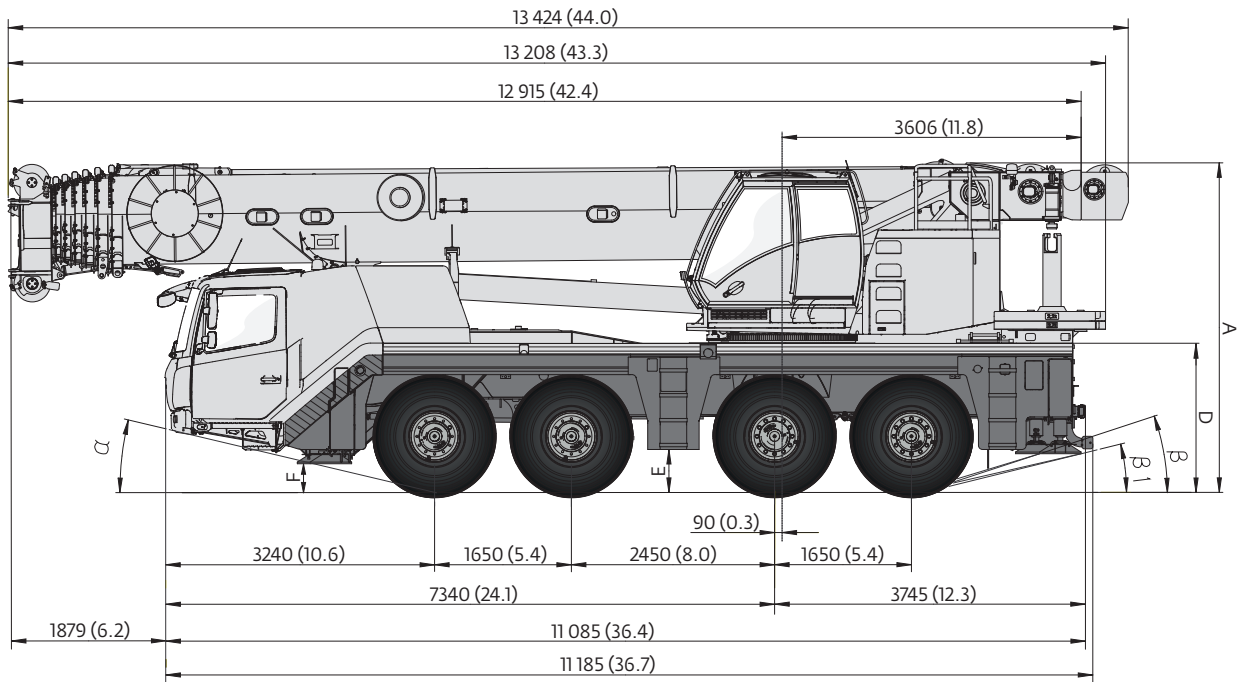

Dimensions shown are in mm (ft).

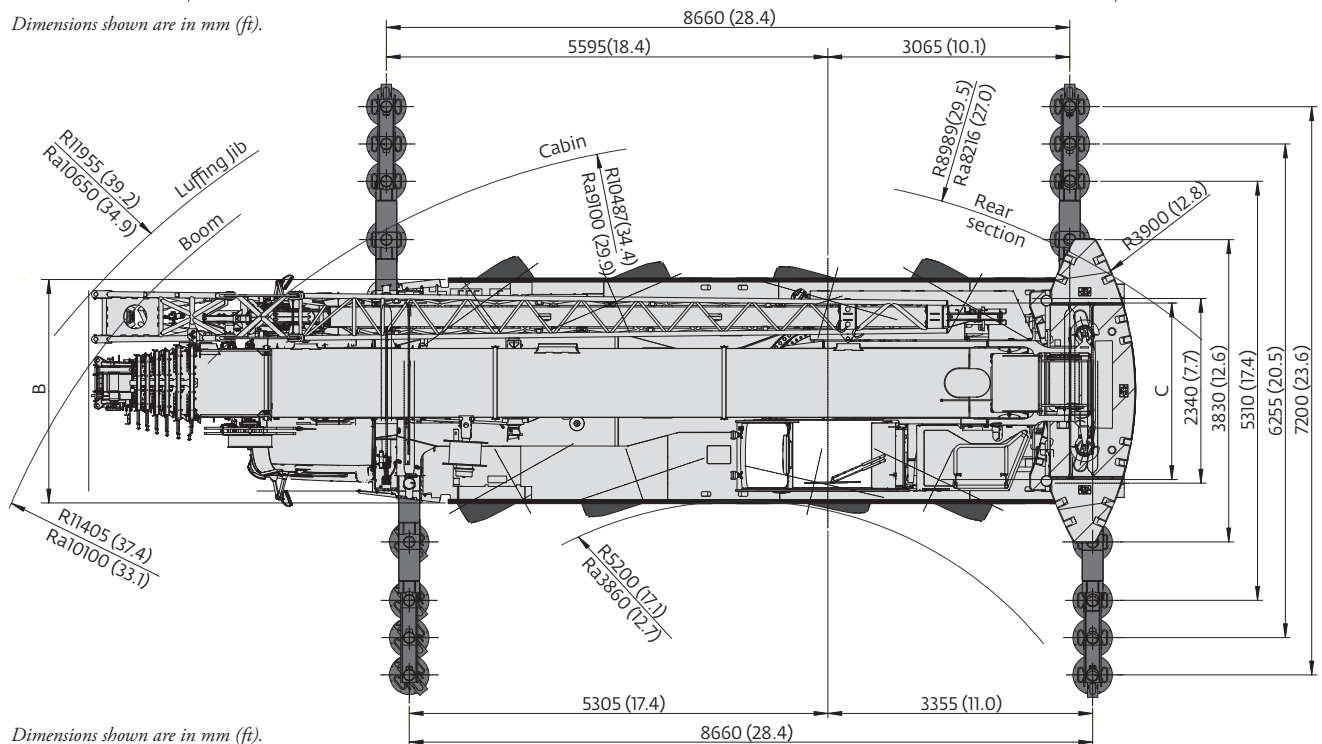

Dimensions shown are in mm (ft).

Ra = Radius all wheels steered

	A	A 126 mm* (0.4)	B	C	D	E	F	a	b	b1
14.00 R25	3940 (12.9)	3810 (12.5)	2550 (8.4)	2320 (7.6)	1750 (5.7)	435 (1.4)	262 (0.9)	14	21	17
16.00 R25	3990 (13.1)	3860 (12.7)	2750 (9.0)	2280 (7.5)	1863 (6.1)	485 (1.6)	292 (1.0)	16	23	19
20.5 R25	3990 (13.1)	3860 (12.7)	2880 (9.4)	2320 (7.6)	1863 (6.1)	485 (1.6)	292 (1.0)	16	23	19

* Lowered

Dimensions

Jib configurations

	A	B	C	D	E
	8,0 m (26.2 ft)	1,7 m (5.6 ft)	1,6 m (5.2 ft)	8,6 m (28.2 ft)	6,5 (21.3 ft)
11,1 m (36.4 ft)	-	x	x	x	-
17,6 m (57.7 ft)	-	x	x	x	x
19,1 m (62.7 ft)	x	x	x	x	-
25,6 m (84.0 ft)	x	x	x	x	x
3,5 m (11.5 ft)	-	x	x	-	-
11,5 m (37.7 ft)	x	x	x	-	-

Dimensions shown are in mm (ft).

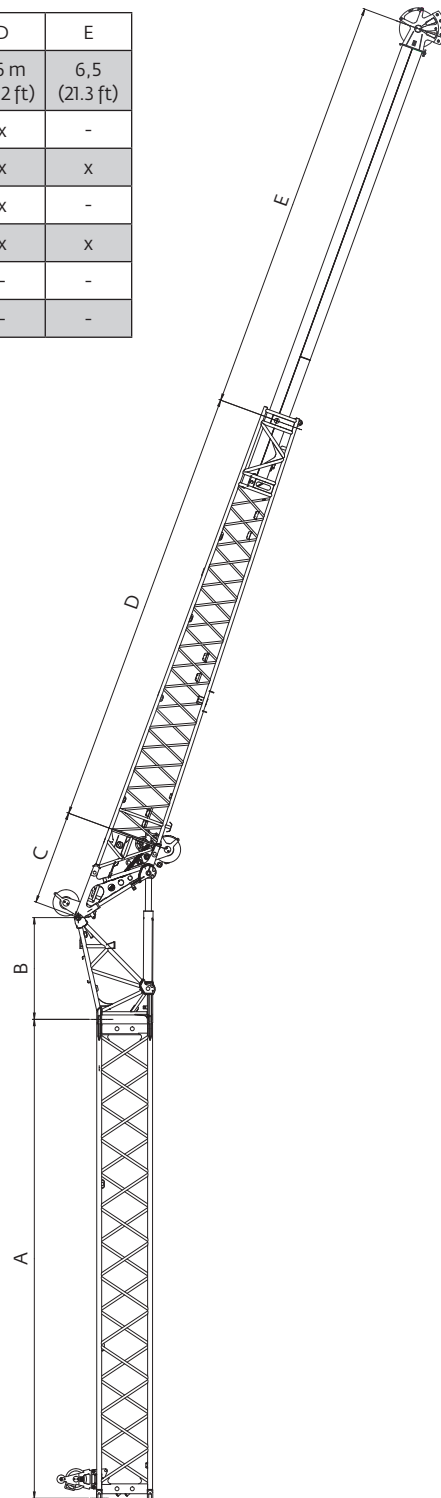

Dimensions

Hose reel

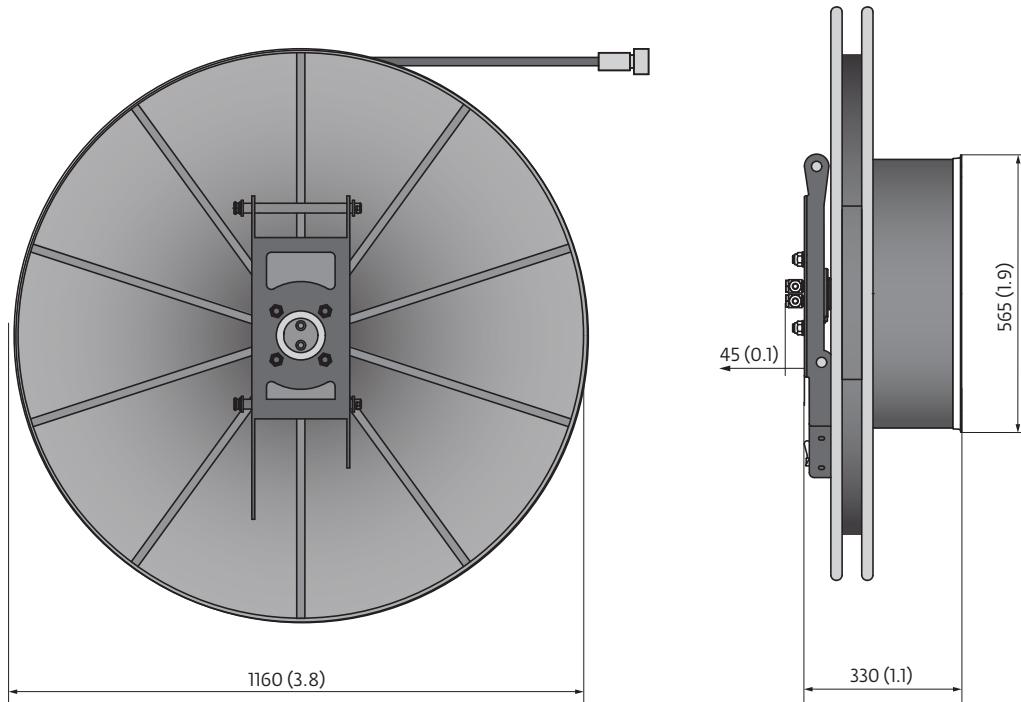

Dimensions shown are in mm (ft).

lb	364
----	-----

Counterweight

Counterweight

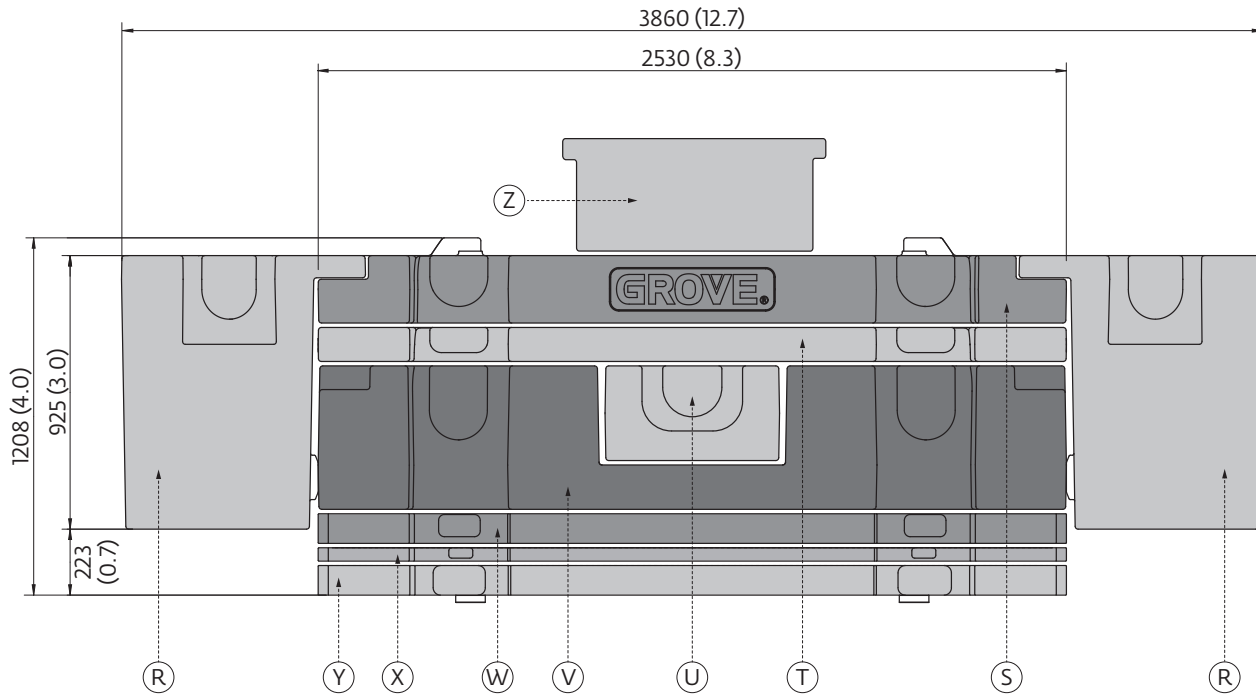

Dimensions shown are in mm (ft).

	Z 0,8 t (0.9 USt)	Y 2,7 t (3.0 USt)	X 1,0 t (1.1 USt)	W 2,1 t (2.3 USt)	V 7,1 t (7.8 USt)	U 1,5 t (1.7 USt)	T 2,2 t (2.4 USt)	S 4,0 t (4.4 USt)	R 2,4 t (2.6 USt)
0,8 t (0.9 USt)	x								
4,5 t (4.9 USt)	x	x	x						
5,7 t (6.3 USt)	x	x					x		
6,7 t (7.4 USt)	x	x	x				x		
8,5 t (9.4 USt)	x	x	x					x	
11,6 t (12.8 USt)	x	x	x		x				
13,1 t (14.4 USt)	x	x	x		x	x			
14,9 t (16.4 USt)	x	x		x	x		x		
17,4 t (19.2 USt)	x	x	x	x	x	x	x		
19,9 t (21.9 USt)	x	x	x	x	x		x	x	
21,4 t (23.5 USt)	x	x	x	x	x	x	x	x	
24,0 t (26.4 USt)	x	x	x	x	x	x		x	2 x
26,2 t (28.9 USt)	x	x	x	x	x	x	x	x	2 x



Lifting Capacity	Sheaves	Weight	Parts of line	Possible load with crane*
100 t (110 USt)	7	1000 kg (2204 lb)	2 - 15	90 t (99 USt)*
80 t (88 USt)	5	750 kg (1653 lb)	2 - 11	77 t (85 USt)
50 t (55 USt)	3	900 kg (1984 lb)	1 - 7	49 t (54 USt)
26 t (29 USt)	1	400 kg (882 lb)	1 - 3	21 t (23 USt)
9 t (10 USt)	H/B	300 kg (660 lb)	1	7 t (8 USt)

* 0° over rear with additional equipment

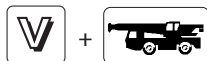

	1	2	3	4	5	6	7	8	9	10	11	12	13	14	15	16	R1	R2	
mph	3.9	4.7	5.8	7.0	8.7	10.5	12.4	15.5	17.4	21.1	25.5	31.1	38.5	46.6	52.8	52.8	3.9	4.8	
mph	1.8	2.2	2.6	3.1	3.9	4.7	5.6	6.8	8.0	9.3	11.8	14.3	17.4	21.1	25.5	30.4	1.8	2.2	70%
	14.00 R25																		



	Infinitely variable	Rope	Max. Single line pull
	0 - 120 m/min (0-394 f/min) Single line	19 mm / 255 m (19 mm / 836 ft)	70,6 kN (15,872 lb)
	0 - 120 m/min (0-394 f/min) Single line	19 mm / 255 m (19 mm / 836 ft)	70,6 kN (15,872 lb)
	0 - 1,7 min ⁻¹		
	-1,5° to + 82° approx. 50 s		
	11,3 to 60,0 m (37.1 to 196.9 ft) approx. 500 s		

Weights

Boom over front

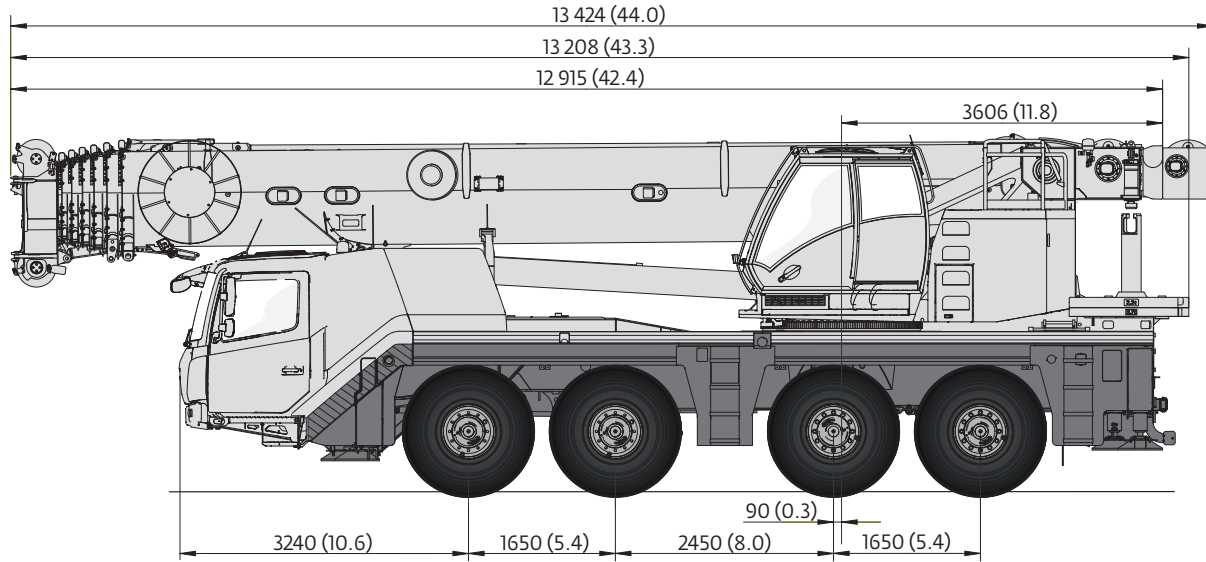

Dimensions shown are in mm (ft).

Basic Weights - kg (lb)	Axles 1 and 2	Axles 1 and 2	Axles 3 and 4	Axles 3 and 4	Total	Total
Mercedes power Tier 4 Final, 16.00 R25 tires, 8x6x8 drive/steer, 2nd oil cooler, nylatron outrigger pads, trailing boom float kit, auxiliary hoist, 3,7t (8200 lb) counterweight on back of carrier, and full fuel tank.	24 400 kg	52,980 lb	22 640 kg	49,900 lb	46 670 kg	102,880
Additions						
8X8X8 drive/steer	224 kg	537 lb	59 kg	129 lb	303 kg	666 lb
Spare wheel 14.00 R25 XGC steel rim with stowage	-206 kg	-455 lb	477 kg	1052 lb	271 kg	597 lb
Spare wheel 16.00 R25 XGC steel rim with stowage	-247 kg	-544 lb	571 kg	1258 lb	324 kg	714 lb
Spare wheel 20.5 R25 XGC steel rim with stowage	-295 kg	-650 lb	682 kg	1503 lb	387 kg	853 lb
Brackets for hydraulic swingaway	303 kg	667 lb	-136 kg	-300 lb	167 kg	367 lb
Hose reel for hydraulic swingaway	343 kg	755 lb	-167 kg	-367 lb	176 kg	388 lb
11,1 m - 17,6 m (36.4 ft - 57.8 ft) hydraulic swingaway	1895 kg	4178 lb	-280 kg	-618 lb	1615 kg	3560 lb
Auxiliary hoist	-737 kg	-1626 lb	1839 kg	4055 lb	1102 kg	2429 lb
Substitutions						
14.00R25 tires	-212 kg	-468 lb	-212 kg	-468 lb	-424 kg	-936 lb
20.5R25 tires	252 kg	555 lb	252 kg	555 lb	504 kg	1110 lb
Removals						
Boom assembly w/o lift cylinder	-12 335 kg	-27,195 lb	-415 kg	-914 lb	-12,750 kg	-28,109 lb
Front outriggers	-1980 kg	-4366 lb	-667 kg	-1471 lb	-1313 kg	-2895 lb
Rear outriggers	936 kg	2064 lb	-2489 kg	-5488 lb	-1553 kg	-3424 lb
Front and rear nylatron outrigger floats	-59 kg	-131 lb	-72 kg	-159 lb	-131 kg	-290 lb

Weights

Trailing Boom

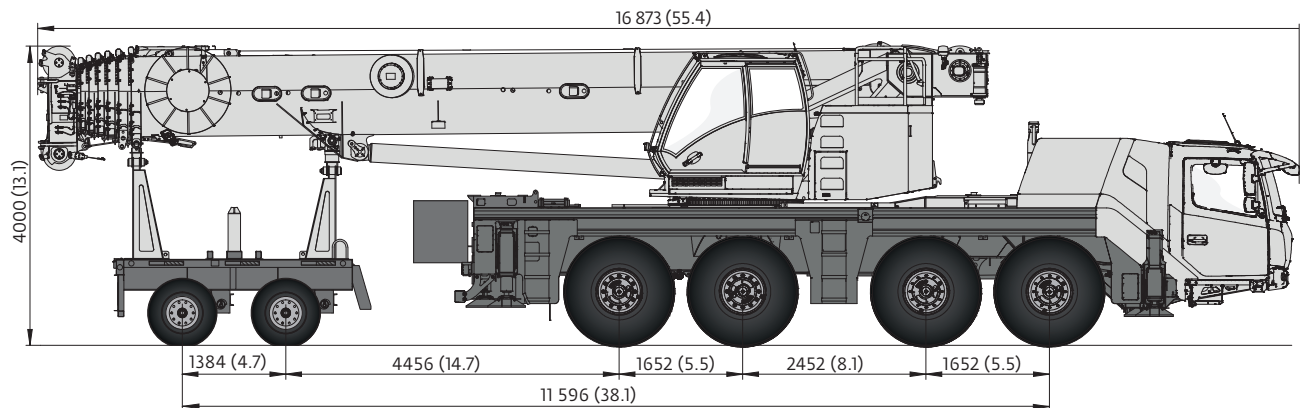

Dimensions shown are in mm (ft).

Basic Weights - kg (lb)	Axles 1 and 2	Axles 1 and 2	Axles 3 and 4	Axles 3 and 4	Dolly	Dolly	Total	Total
GMK 4100L-1 Mercedes power Tier 4 Final with: 20.5R25 tires, 8x6x8 drive/steer, 11,1 m - 17,6 m (36.4 ft - 57.8 ft) hydraulic swingaway, 2 line boom nose, 2nd oil cooler, nylatron outrigger pads, auxiliary hoist, full fuel tank, 2 axle boom dolly (3087 kg/6800 lb)	19 900 kg	43,880 lb	18 920 kg	41,700 lb	13 517 kg	29,810 lb	51 343 kg	115,390 lb
Removals								
Brackets for hydraulic swingaway incl. hose reel	40 kg	60 lb	10 kg	20 lb	-380 kg	-850 lb	-330 kg	-770 lb
11,1 m - 17,6 m (36.4 ft - 57.8 ft) hydraulic swingaway	-300 kg	-640 lb	-100 kg	-220 lb	-1220 kg	-2700 lb	-1620 kg	-3560 lb
Auxiliary hoist	-1120 kg	-2480 lb	20 kg	80 lb	0 kg	-30 lb	-1100 kg	-2430 lb
2 line boom nose	40 kg	60 lb	0 kg	20 lb	-140 kg	-330 lb	-100 kg	-240 lb
Front outriggers	-1985 kg	-4375 lb	670 kg	1480 lb	0 kg	-30 lb	-1315 kg	-2895 lb
Rear outriggers	940 kg	2080 lb	-2500 kg	-5480 lb	0 kg	-30 lb	-1560 kg	-3430 lb
Front and rear nylatron outrigger floats	-65 kg	-145 lb	-65 kg	-145 lb	0 kg	0 lb	-130 kg	-290 lb
Substitutions								
8X8X8 drive/steer	240 kg	530 lb	60 kg	130 lb	0 kg	0 lb	300 kg	660 lb
14.00R25 tires	-460 kg	-1020 lb	-460 kg	-1020 lb	0 kg	0 lb	-920 kg	-2040 lb
16.00R25 tires	-250 kg	-550 lb	-250 kg	-550 lb	0 kg	0 lb	-500 kg	-110 lb

Working range

Main boom



11,3 m - 60,0 m (37 ft - 197 ft)



7,2 m (23.6 ft)



360°

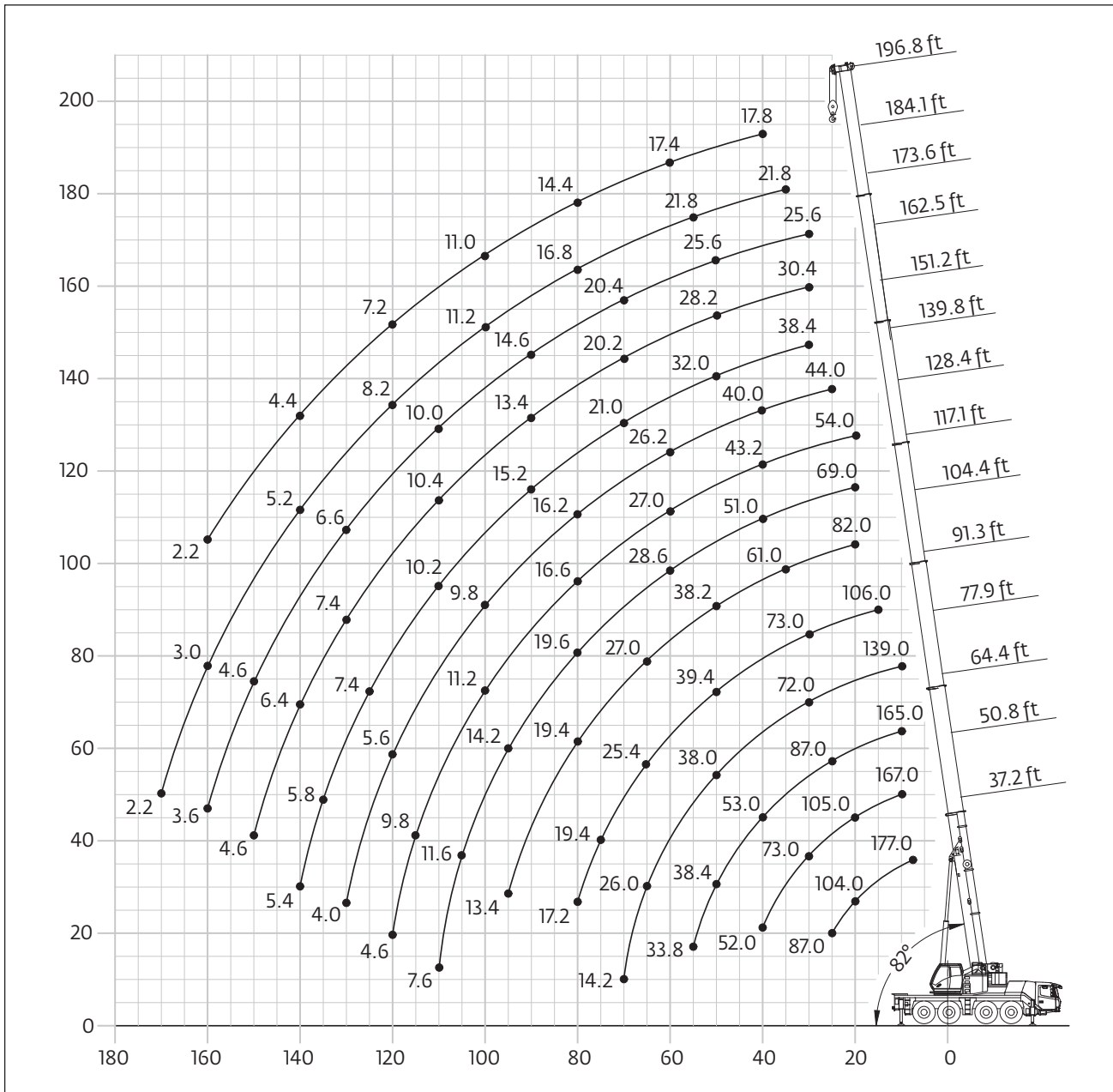

	Hook block (USt)	H (ft)
	110 D	10.2
	88 E/D	9.5
	55 E/D	9.2
	24 E/D	9.2
10 H/B	7.7	

THIS CHART IS ONLY A GUIDE AND SHOULD NOT BE USED TO OPERATE THE CRANE.
 The individual crane's load chart, operating instructions and other instructional plates must be read and understood prior to operating the crane

Load charts

Main boom



11,3 m - 60,0 m (37 ft - 197 ft)



7,2 m (23.6 ft)



360°



26,2 t (57,700 lb)



Pounds x 1000

Feet	37.2	50.8	64.4	77.9	91.3	104.4	117.1	128.4	139.8	151.2	162.5	173.5	184.1	190.4	196.9	Feet
8.0	230.0*															8.0
9.0	177.0															9.0
10.0	166.0	167.0	165.0	139.0												10.0
15.0	129.0	130.0	130.0	129.0	106.0											15.0
20.0	104.0	105.0	104.0	104.0	100.0	82.0	69.0	54.0								20.0
25.0	87.0	88.0	87.0	86.0	87.0	76.0	67.0	54.0	44.0							25.0
30.0		73.0	72.0	72.0	73.0	69.0	63.0	53.0	44.0	38.4	30.4	25.6				30.0
35.0		62.0	61.0	62.0	61.0	61.0	58.0	48.0	43.0	38.2	30.4	25.6	21.8			35.0
40.0		52.0	53.0	53.0	51.0	51.0	51.0	43.2	40.0	36.8	30.4	25.6	21.8	19.0	17.8	40.0
45.0			45.0	45.0	45.0	43.0	43.2	39.4	36.6	34.6	30.0	25.6	21.8	19.0	17.8	45.0
50.0			38.4	38.0	39.4	38.2	37.2	35.4	33.4	32.0	28.2	25.6	21.8	19.0	17.8	50.0
55.0			33.8	34.4	33.8	34.8	32.6	30.8	30.0	29.6	26.4	24.6	21.8	18.8	17.6	55.0
60.0				29.8	29.2	30.8	28.6	27.0	26.2	26.6	24.8	23.2	21.8	18.8	17.4	60.0
65.0				26.0	25.4	27.0	25.4	23.8	23.2	23.6	22.8	21.8	20.6	18.4	17.2	65.0
70.0				14.2	22.2	23.8	23.6	21.2	20.4	21.0	20.2	20.4	19.6	18.0	16.6	70.0
75.0					19.4	21.0	22.0	18.8	18.2	18.6	18.0	18.2	18.4	17.2	15.4	75.0
80.0					17.2	19.4	19.6	16.6	16.2	17.2	16.2	16.8	16.8	16.2	14.4	80.0
85.0						18.4	17.6	14.6	14.4	16.2	14.4	15.6	15.0	15.2	13.6	85.0
90.0						15.0	15.8	12.8	12.8	15.2	13.4	14.6	13.6	13.8	12.6	90.0
95.0						13.4	14.2	11.8	11.2	14.0	12.6	13.4	12.4	12.4	11.8	95.0
100.0							13.0	11.2	9.8	12.6	11.8	12.2	11.2	11.2	11.0	100.0
105.0							11.6	10.6	8.6	11.4	11.0	11.0	10.0	10.2	9.8	105.0
110.0							7.6	10.2	7.4	10.2	10.4	10.0	9.4	9.2	9.0	110.0
115.0								9.8	6.4	9.2	9.6	9.0	8.8	8.4	8.0	115.0
120.0								4.6	5.6	8.4	8.6	8.0	8.2	7.6	7.2	120.0
125.0									4.8	7.4	7.8	7.2	7.4	6.6	6.4	125.0
130.0									4.0	6.8	7.4	6.6	6.6	5.8	5.8	130.0
135.0										6.0	7.0	6.2	5.8	5.2	5.0	135.0
140.0										5.4	6.4	5.8	5.2	4.6	4.4	140.0
145.0											5.8	5.2	4.6	4.0	3.8	145.0
150.0											4.6	4.6	4.0	3.4	3.2	150.0
155.0												4.0	3.4	2.8	2.6	155.0
160.0												3.6	3.0	2.4	2.2	160.0
165.0													2.6	2.0		165.0
170.0														2.2		170.0

* Over rear with special equipment.

THIS CHART IS ONLY A GUIDE AND SHOULD NOT BE USED TO OPERATE THE CRANE.

The individual crane's load chart, operating instructions and other instructional plates must be read and understood prior to operating the crane

Load charts

Main boom



11,3 m - 60,0 m (37 ft - 197 ft)



7,2 m (23.6 ft)



360°



24 t (52,900 lb)



Pounds x 1000

Feet	37.2	50.8	64.4	77.9	91.3	104.4	117.1	128.4	139.8	151.2	162.5	173.5	184.1	190.4	196.9	Feet
9.0	176.0															9.0
10.0	166.0	167.0	165.0	139.0												10.0
15.0	129.0	130.0	129.0	129.0	106.0											15.0
20.0	104.0	105.0	104.0	104.0	100.0	82.0	69.0	69.0								20.0
25.0	86.0	88.0	87.0	86.0	87.0	76.0	67.0	67.0	44.0							25.0
30.0		72.0	71.0	71.0	72.0	69.0	63.0	63.0	44.0	38.4	30.4	25.6				30.0
35.0		60.0	60.0	61.0	58.0	58.0	57.0	57.0	43.0	38.2	30.4	25.6	21.8			35.0
40.0		51.0	52.0	51.0	50.0	48.0	48.0	48.0	40.0	36.8	30.4	25.6	21.8	19.0	17.8	40.0
45.0			43.0	42.6	43.0	41.6	40.6	40.6	36.6	34.6	30.0	25.6	21.8	19.0	17.8	45.0
50.0			36.4	37.4	37.0	37.4	35.0	35.0	32.2	32.0	28.2	25.6	21.8	19.0	17.8	50.0
55.0			32.0	32.4	31.8	32.8	30.4	30.4	28.0	28.2	26.4	24.6	21.8	18.8	17.6	55.0
60.0				27.8	27.2	28.8	26.8	26.8	24.4	24.8	24.0	23.2	21.8	18.8	17.4	60.0
65.0				24.4	23.6	25.2	25.0	25.0	21.4	21.8	21.2	21.4	20.6	18.4	17.2	65.0
70.0				14.2	20.6	22.2	23.2	23.2	19.0	19.4	18.8	19.2	19.2	18.0	16.6	70.0
75.0					18.0	20.2	20.6	20.6	16.8	18.2	16.6	18.0	17.2	17.2	15.4	75.0
80.0					15.8	19.0	18.2	18.2	14.8	17.2	15.4	16.6	15.4	15.4	14.4	80.0
85.0					4.0	17.2	16.4	16.4	13.2	15.8	14.4	14.8	13.8	14.0	13.6	85.0
90.0						15.4	14.6	14.6	12.0	14.4	13.4	13.4	12.4	12.6	12.2	90.0
95.0						12.2	13.2	13.2	11.4	13.0	12.6	12.2	11.4	11.4	11.0	95.0
100.0							11.8	11.8	10.6	11.6	11.8	11.0	10.6	10.2	9.8	100.0
105.0							10.6	10.6	10.0	10.4	10.8	10.0	10.0	9.2	8.8	105.0
110.0								10.2	9.4	9.4	9.6	9.0	9.0	8.2	8.0	110.0
115.0								9.8	9.0	8.4	8.6	8.0	8.2	7.4	7.2	115.0
120.0								4.6	8.4	7.4	8.2	7.6	7.2	6.6	6.4	120.0
125.0									8.0	6.6	7.8	7.0	6.4	5.8	5.6	125.0
130.0									3.2	6.0	7.0	6.4	5.8	5.0	5.0	130.0
135.0										5.2	6.4	5.6	5.0	4.4	4.2	135.0
140.0										4.6	5.8	5.0	4.4	3.8	3.6	140.0
145.0											5.2	4.4	3.8	3.2	3.0	145.0
150.0											3.8	4.0	3.4	2.6	2.4	150.0
155.0												3.4	2.8	2.2	2.0	155.0
160.0												3.0	2.4			160.0
165.0													2.0			165.0

THIS CHART IS ONLY A GUIDE AND SHOULD NOT BE USED TO OPERATE THE CRANE.

The individual crane's load chart, operating instructions and other instructional plates must be read and understood prior to operating the crane

Load charts

Main boom



11,3 m - 60,0 m (37 ft - 197 ft)



7,2 m (23.6 ft)



360°



21,4 t (47,100 lb)



Pounds x 1000

Feet	37.2	50.8	64.4	77.9	91.3	104.4	117.1	128.4	139.8	151.2	162.5	173.5	184.1	190.4	196.9	Feet
9.0	176.0															9.0
10.0	166.0	166.0	165.0	139.0												10.0
15.0	129.0	129.0	129.0	129.0	106.0											15.0
20.0	104.0	105.0	104.0	103.0	100.0	82.0	69.0	54.0								20.0
25.0	85.0	87.0	86.0	85.0	87.0	76.0	67.0	54.0	44.0							25.0
30.0		71.0	70.0	70.0	67.0	66.0	63.0	53.0	44.0	38.4	30.4	25.6				30.0
35.0		59.0	59.0	58.0	56.0	53.0	53.0	48.0	43.0	38.2	30.4	25.6	21.8			35.0
40.0		48.0	49.0	47.0	47.0	46.0	44.0	42.0	40.0	36.8	30.4	25.6	21.8	19.0	17.8	40.0
45.0			39.8	41.0	39.8	40.2	37.6	35.6	34.4	34.4	30.0	25.6	21.8	19.0	17.8	45.0
50.0			34.8	35.0	34.0	34.6	32.2	30.4	29.4	29.6	28.2	25.6	21.8	19.0	17.8	50.0
55.0			29.6	29.8	29.2	30.2	28.4	26.2	25.4	25.8	25.0	24.6	21.8	18.8	17.6	55.0
60.0				26.2	25.0	26.4	26.6	22.8	22.2	22.6	21.8	22.0	21.8	18.8	17.4	60.0
65.0				24.0	21.4	23.0	24.0	20.0	19.4	20.6	19.6	20.4	19.6	18.4	17.2	65.0
70.0				14.2	19.0	21.4	21.2	17.6	17.0	19.4	18.2	18.6	17.4	17.4	16.6	70.0
75.0					18.0	19.6	18.8	15.4	15.0	17.6	16.6	16.6	15.4	15.6	15.2	75.0
80.0					14.2	17.4	16.6	14.2	13.8	15.8	15.4	14.8	13.8	14.0	13.6	80.0
85.0						15.6	14.8	13.4	13.0	14.2	14.4	13.4	13.0	12.4	12.2	85.0
90.0						14.0	13.2	12.6	12.0	12.8	13.0	12.0	12.0	11.2	10.8	90.0
95.0						10.8	11.8	11.8	11.4	11.6	11.8	10.8	10.8	10.0	9.6	95.0
100.0							10.6	11.2	10.6	10.2	10.6	9.8	9.6	9.0	8.6	100.0
105.0							9.4	10.6	10.0	9.2	9.6	9.2	8.8	8.0	7.6	105.0
110.0								5.4	9.4	8.2	9.2	8.6	7.8	7.0	6.8	110.0
115.0								4.6	8.6	7.2	8.4	7.6	7.0	6.2	6.0	115.0
120.0								3.8	7.6	6.4	7.6	6.8	6.2	5.6	5.4	120.0
125.0									7.0	5.6	6.8	6.0	5.4	4.8	4.6	125.0
130.0									2.2	5.0	6.0	5.4	4.8	4.2	4.0	130.0
135.0										4.4	5.4	4.8	4.2	3.4	3.2	135.0
140.0										3.8	4.8	4.2	3.6	2.8	2.8	140.0
145.0											4.2	3.6	3.0	2.4	2.2	145.0
150.0											3.0	3.0	2.4			150.0
155.0												2.6	2.0			155.0
160.0												2.2				160.0

THIS CHART IS ONLY A GUIDE AND SHOULD NOT BE USED TO OPERATE THE CRANE.

The individual crane's load chart, operating instructions and other instructional plates must be read and understood prior to operating the crane

Load charts

Main boom



11,3 m - 60,0 m (37 ft - 197 ft)



7,2 m (23.6 ft)



360°



19,9 t (43,800 lb)



Pounds x 1000

Feet	37.2	50.8	64.4	77.9	91.3	104.4	117.1	128.4	139.8	151.2	162.5	173.5	184.1	190.4	196.9	Feet
9.0	176.0															9.0
10.0	166.0	166.0	165.0	139.0												10.0
15.0	129.0	129.0	129.0	128.0	106.0											15.0
20.0	103.0	105.0	104.0	103.0	100.0	82.0	69.0	54.0								20.0
25.0	84.0	86.0	85.0	84.0	84.0	76.0	67.0	54.0	44.0							25.0
30.0		70.0	69.0	69.0	65.0	63.0	63.0	53.0	44.0	38.4	30.4	25.6				30.0
35.0		57.0	58.0	55.0	55.0	51.0	51.0	48.0	43.0	38.2	30.4	25.6	21.8			35.0
40.0		47.0	47.0	45.0	45.0	45.0	42.4	40.0	38.8	36.8	30.4	25.6	21.8	19.0	17.8	40.0
45.0			39.8	40.0	38.0	38.6	35.8	33.8	32.8	33.0	30.0	25.6	21.8	19.0	17.8	45.0
50.0			33.2	33.4	32.4	33.2	30.8	29.0	28.0	28.2	27.4	25.6	21.8	19.0	17.8	50.0
55.0			28.2	28.4	27.8	28.8	28.4	25.0	24.2	24.6	23.8	23.8	21.8	18.8	17.6	55.0
60.0				26.2	23.6	25.2	25.6	21.6	21.0	22.0	21.2	21.8	21.0	18.8	17.4	60.0
65.0				22.8	20.4	22.8	22.8	18.8	18.2	20.6	19.6	19.8	18.6	18.4	17.2	65.0
70.0				14.2	19.0	21.0	20.2	16.6	16.2	18.6	18.2	17.6	16.4	16.4	16.0	70.0
75.0					18.0	18.6	17.8	15.2	15.0	16.6	16.6	15.6	15.0	14.6	14.2	75.0
80.0					13.2	16.6	15.8	14.2	13.8	15.0	15.2	14.0	13.8	13.0	12.8	80.0
85.0						14.8	14.0	13.4	13.0	13.4	13.6	12.6	12.4	11.6	11.4	85.0
90.0						13.2	12.4	12.6	12.0	12.0	12.2	11.2	11.2	10.4	10.0	90.0
95.0						10.2	11.0	11.8	11.4	10.8	11.0	10.4	10.0	9.2	9.0	95.0
100.0							9.8	11.2	10.6	9.6	10.2	9.8	9.0	8.2	8.0	100.0
105.0							8.8	10.2	9.8	8.4	9.6	9.0	8.0	7.2	7.0	105.0
110.0										7.6	8.6	8.0	7.2	6.4	6.2	110.0
115.0										6.6	7.8	7.0	6.4	5.6	5.4	115.0
120.0										5.8	7.0	6.2	5.6	5.0	4.8	120.0
125.0										5.0	6.2	5.6	5.0	4.2	4.0	125.0
130.0										4.4	5.6	4.8	4.2	3.6	3.4	130.0
135.0										3.8	4.8	4.2	3.6	3.0	2.8	135.0
140.0										3.4	4.4	3.6	3.0	2.4	2.2	140.0
145.0											3.8	3.2	2.6			145.0
150.0											2.6	2.6	2.0			150.0
155.0												2.2				155.0

THIS CHART IS ONLY A GUIDE AND SHOULD NOT BE USED TO OPERATE THE CRANE.

The individual crane's load chart, operating instructions and other instructional plates must be read and understood prior to operating the crane

Load charts

Main boom



11,3 m - 60,0 m (37 ft - 197 ft)



7,2 m (23.6 ft)



360°



17,4 t (38,300 lb)



Pounds x 1000

Feet	37.2	50.8	64.4	77.9	91.3	104.4	117.1	128.4	139.8	151.2	162.5	173.5	184.1	190.4	196.9	Feet
9.0	175.0															9.0
10.0	165.0	166.0	164.0	139.0												10.0
15.0	128.0	129.0	129.0	128.0	106.0											15.0
20.0	103.0	105.0	104.0	103.0	100.0	82.0	69.0	54.0								20.0
25.0	83.0	84.0	83.0	81.0	78.0	76.0	67.0	54.0	44.0							25.0
30.0		68.0	67.0	64.0	63.0	59.0	58.0	53.0	44.0	38.4	30.4	25.6				30.0
35.0		54.0	54.0	51.0	51.0	51.0	47.0	45.0	43.0	38.2	30.4	25.6	21.8			35.0
40.0		43.0	43.6	44.0	41.8	42.0	39.0	36.8	35.6	35.6	30.4	25.6	21.8	19.0	17.8	40.0
45.0			36.6	37.0	35.0	35.6	33.0	31.0	30.0	30.2	29.2	25.6	21.8	19.0	17.8	45.0
50.0			30.6	30.8	29.8	30.4	30.4	26.4	25.6	25.8	25.0	25.0	21.8	19.0	17.8	50.0
55.0			25.8	27.8	25.4	26.4	26.8	22.6	22.0	23.6	22.8	23.0	21.8	18.8	17.6	55.0
60.0				24.0	21.6	24.2	23.6	19.6	19.0	21.6	21.2	20.2	19.0	18.8	17.4	60.0
65.0				20.8	20.2	21.8	20.8	17.6	17.6	19.0	19.2	17.8	17.4	16.8	16.4	65.0
70.0				14.2	19.0	19.2	18.4	16.4	16.2	16.8	17.0	15.8	15.6	14.8	14.4	70.0
75.0					17.2	16.8	16.0	15.2	15.0	15.0	15.2	14.2	14.0	13.0	12.8	75.0
80.0					11.8	15.0	14.2	14.2	13.8	13.4	13.6	13.0	12.4	11.6	11.2	80.0
85.0						13.2	12.4	13.4	13.0	12.0	12.4	12.0	11.0	10.2	10.0	85.0
90.0						12.6	11.0	12.6	12.0	10.6	11.6	10.8	9.8	9.0	8.8	90.0
95.0						8.8	9.8	11.2	10.8	9.4	10.6	9.6	8.8	8.0	7.6	95.0
100.0							8.6	10.0	9.6	8.4	9.6	8.6	7.8	7.0	6.8	100.0
105.0							8.2	9.0	8.6	7.4	8.4	7.8	7.0	6.2	5.8	105.0
110.0							5.0	8.2	7.8	6.4	7.6	6.8	6.2	5.4	5.0	110.0
115.0								7.4	6.8	5.6	6.6	6.0	5.4	4.6	4.4	115.0
120.0								2.2	6.2	4.8	6.0	5.2	4.6	4.0	3.8	120.0
125.0									5.4	4.2	5.2	4.6	4.0	3.4	3.2	125.0
130.0										3.6	4.6	4.0	3.4	2.6	2.4	130.0
135.0										3.0	4.0	3.4	2.8	2.0	2.0	135.0
140.0										2.4	3.4	2.8	2.2			140.0
145.0											3.0	2.4				145.0

THIS CHART IS ONLY A GUIDE AND SHOULD NOT BE USED TO OPERATE THE CRANE.

The individual crane's load chart, operating instructions and other instructional plates must be read and understood prior to operating the crane

Load charts

Main boom



11,3 m - 60,0 m (37 ft - 197 ft)



7,2 m (23.6 ft)



360°



14,9 t (32,800 lb)



Pounds x 1000

Feet	37.2	50.8	64.4	77.9	91.3	104.4	117.1	128.4	139.8	151.2	162.5	173.5	184.1	190.4	196.9	Feet
9.0	175.0															9.0
10.0	165.0	165.0	164.0	139.0												10.0
15.0	128.0	128.0	128.0	128.0	106.0											15.0
20.0	103.0	104.0	103.0	103.0	100.0	82.0	69.0	54.0								20.0
25.0	81.0	83.0	82.0	79.0	73.0	71.0	67.0	54.0	44.0							25.0
30.0	65.0	65.0	64.0	60.0	59.0	56.0	54.0	51.0	44.0	38.4	30.4	25.6				30.0
35.0		50.0	50.0	50.0	47.0	47.0	43.6	41.0	39.4	38.2	30.4	25.6	21.8			35.0
40.0		40.0	41.4	40.8	38.4	38.8	36.0	33.8	32.6	32.6	30.4	25.6	21.8	19.0	17.8	40.0
45.0			33.8	34.0	32.0	32.6	32.8	28.4	27.4	27.6	26.6	25.6	21.8	19.0	17.8	45.0
50.0			28.4	30.2	27.2	27.8	28.2	24.0	23.2	25.2	24.4	24.2	21.8	19.0	17.8	50.0
55.0			23.4	25.6	23.2	26.0	24.6	20.6	20.6	22.4	22.4	21.0	19.8	18.8	17.6	55.0
60.0				21.8	21.6	23.0	21.4	19.0	19.0	19.6	19.6	18.4	18.2	17.2	16.8	60.0
65.0				18.8	20.2	20.0	18.8	17.6	17.6	17.2	17.4	16.8	16.0	15.0	14.6	65.0
70.0				12.6	17.6	17.4	16.6	16.4	16.2	15.2	15.4	15.2	14.0	13.2	12.8	70.0
75.0					15.6	15.2	14.4	15.2	15.0	13.4	14.2	13.4	12.4	11.6	11.2	75.0
80.0					11.4	13.8	12.6	14.2	13.8	12.0	13.0	12.0	11.0	10.2	9.8	80.0
85.0						12.8	11.0	12.6	12.2	10.6	11.6	10.6	9.6	8.8	8.6	85.0
90.0						8.8	9.8	11.2	10.8	9.4	10.4	9.4	8.6	7.8	7.4	90.0
95.0						7.6	9.2	10.0	9.6	8.2	9.4	8.4	7.6	6.8	6.4	95.0
100.0							8.6	9.0	8.4	7.2	8.4	7.4	6.6	5.8	5.6	100.0
105.0							8.2	8.0	7.6	6.2	7.4	6.6	5.8	5.0	4.8	105.0
110.0								7.0	6.6	5.4	6.4	5.8	5.0	4.4	4.0	110.0
115.0								6.4	5.8	4.6	5.6	5.0	4.4	3.6	3.4	115.0
120.0									5.2	3.8	5.0	4.4	3.6	3.0	2.8	120.0
125.0									4.6	3.2	4.4	3.6	3.0	2.4	2.2	125.0
130.0										2.6	3.8	3.0	2.4			130.0
135.0										2.2	3.2	2.4	1.8			135.0
140.0											2.6	2.0				140.0
145.0											2.2					145.0

THIS CHART IS ONLY A GUIDE AND SHOULD NOT BE USED TO OPERATE THE CRANE.

The individual crane's load chart, operating instructions and other instructional plates must be read and understood prior to operating the crane

Load charts

Main boom



11,3 m - 60,0 m (37 ft - 197 ft)



7,2 m (23.6 ft)



360°



13,1 t (28,800 lb)



Pounds x 1000

Feet	37.2	50.8	64.4	77.9	91.3	104.4	117.1	128.4	139.8	151.2	162.5	173.5	184.1	190.4	196.9	Feet
9.0	175.0															9.0
10.0	165.0	165.0	164.0	139.0												10.0
15.0	128.0	128.0	128.0	128.0	106.0											15.0
20.0	102.0	104.0	103.0	100.0	95.0	82.0	69.0	54.0								20.0
25.0	79.0	81.0	77.0	74.0	72.0	66.0	65.0	54.0	44.0							25.0
30.0		61.0	60.0	57.0	55.0	55.0	51.0	47.0	44.0	38.4	30.4	25.6				30.0
35.0		47.0	49.0	47.0	43.8	44.0	40.8	38.2	36.8	36.8	30.4	25.6	21.8			35.0
40.0		40.0	38.8	38.2	35.8	36.2	35.4	31.4	30.2	30.4	29.2	25.6	21.8	19.0	17.8	40.0
45.0			31.4	33.8	29.8	30.4	30.8	26.2	25.2	27.0	26.0	24.6	21.8	19.0	17.8	45.0
50.0			27.2	28.2	25.2	27.8	26.4	22.4	22.6	24.0	24.0	22.4	21.0	19.0	17.8	50.0
55.0			22.8	23.8	23.2	24.4	22.8	20.6	20.6	20.8	20.8	19.6	19.2	18.2	17.6	55.0
60.0				20.2	21.6	21.4	19.8	19.0	19.0	18.0	18.2	17.8	16.8	15.8	15.4	60.0
65.0				17.6	18.8	18.4	17.4	17.6	17.6	15.8	16.6	15.8	14.6	13.8	13.4	65.0
70.0				11.2	16.4	16.0	15.2	16.4	15.8	13.8	15.0	13.8	12.8	12.0	11.6	70.0
75.0					14.4	14.6	13.2	14.8	14.0	12.2	13.2	12.2	11.2	10.4	10.0	75.0
80.0					11.4	13.2	11.6	13.0	12.6	10.8	11.8	10.8	9.8	9.0	8.8	80.0
85.0						12.0	10.4	11.6	11.2	9.4	10.6	9.6	8.6	7.8	7.6	85.0
90.0						10.6	9.8	10.2	9.8	8.4	9.4	8.4	7.6	6.8	6.6	90.0
95.0						6.6	9.2	9.0	8.6	7.4	8.4	7.4	6.6	5.8	5.6	95.0
100.0							8.4	8.0	7.6	6.2	7.4	6.6	5.8	5.0	4.8	100.0
105.0							7.4	7.0	6.6	5.4	6.6	5.8	5.0	4.2	4.0	105.0
110.0								6.2	5.8	4.6	5.6	5.0	4.2	3.6	3.2	110.0
115.0								5.6	5.0	3.8	5.0	4.2	3.6	2.8	2.6	115.0
120.0									4.4	3.2	4.2	3.6	3.0	2.2	2.0	120.0
125.0									3.8	2.6	3.6	3.0	2.4			125.0
130.0										2.0	3.0	2.4				130.0
135.0											2.6					135.0
140.0											2.0					140.0

THIS CHART IS ONLY A GUIDE AND SHOULD NOT BE USED TO OPERATE THE CRANE.

The individual crane's load chart, operating instructions and other instructional plates must be read and understood prior to operating the crane

Load charts

Main boom



11,3 m - 60,0 m (37 ft - 197 ft)



7,2 m (23.6 ft)



360°



11,6 (25,500 lb)



Pounds x 1000

Feet	37.2	50.8	64.4	77.9	91.3	104.4	117.1	128.4	139.8	151.2	162.5	173.5	184.1	190.4	196.9	Feet
9.0	174.0															9.0
10.0	164.0	165.0	163.0	139.0												10.0
15.0	128.0	128.0	128.0	127.0	106.0											15.0
20.0	101.0	103.0	102.0	95.0	90.0	82.0	69.0	54.0								20.0
25.0	77.0	80.0	76.0	71.0	69.0	63.0	62.0	54.0	44.0							25.0
30.0		59.0	57.0	56.0	52.0	52.0	48.0	45.0	43.2	38.4	30.4	25.6				30.0
35.0		45.0	47.0	44.0	41.6	41.8	38.6	36.2	34.8	34.6	30.4	25.6	21.8			35.0
40.0		40.0	36.6	37.4	33.8	34.4	34.4	29.6	28.4	29.0	27.6	25.6	21.8	19.0	17.8	40.0
45.0			30.8	32.0	28.0	30.2	29.0	24.6	24.8	26.4	26.0	24.6	21.8	19.0	17.8	45.0
50.0			25.8	26.6	25.0	26.6	24.8	22.4	22.6	22.6	22.6	21.2	19.8	19.0	17.8	50.0
55.0			21.4	22.4	23.2	23.0	21.4	20.6	20.6	19.4	19.6	19.2	18.0	17.0	16.6	55.0
60.0				19.0	20.4	20.0	18.6	19.0	19.0	16.8	17.8	16.8	15.6	14.6	14.2	60.0
65.0				17.2	17.6	17.4	16.2	17.6	16.6	14.8	15.8	14.6	13.6	12.6	12.2	65.0
70.0				10.2	15.4	15.6	14.2	15.6	14.8	12.8	14.0	12.8	11.8	11.0	10.6	70.0
75.0					13.4	14.0	12.2	13.8	13.0	11.2	12.4	11.4	10.4	9.4	9.2	75.0
80.0					11.4	12.6	11.0	12.2	11.6	9.8	11.0	10.0	9.0	8.2	7.8	80.0
85.0						11.2	10.4	10.8	10.2	8.6	9.8	8.8	7.8	7.0	6.8	85.0
90.0						9.8	9.8	9.4	9.0	7.6	8.6	7.6	6.8	6.0	5.8	90.0
95.0						6.0	8.6	8.4	7.8	6.6	7.6	6.8	5.8	5.2	4.8	95.0
100.0							7.6	7.4	7.0	5.6	6.8	5.8	5.0	4.2	4.0	100.0
105.0							6.8	6.4	6.0	4.8	5.8	5.2	4.2	3.6	3.2	105.0
110.0								5.6	5.2	4.0	5.0	4.4	3.6	2.8	2.6	110.0
115.0								5.0	4.4	3.2	4.4	3.6	3.0	2.2	2.0	115.0
120.0									3.8	2.6	3.6	3.0	2.4			120.0
125.0									3.2	2.0	3.0	2.4				125.0
130.0											2.6					130.0
135.0											2.0					135.0
140.0											2.0					140.0

THIS CHART IS ONLY A GUIDE AND SHOULD NOT BE USED TO OPERATE THE CRANE.

The individual crane's load chart, operating instructions and other instructional plates must be read and understood prior to operating the crane

Load charts

Main boom



11,3 m - 60,0 m (37 ft - 197 ft)



7,2 m (23.6 ft)



360°



8,5 t (18,700 lb)



Pounds x 1000

Feet	37.2	50.8	64.4	77.9	91.3	104.4	117.1	128.4	139.8	151.2	162.5	173.5	184.1	190.4	196.9	Feet
9.0	174.0															9.0
10.0	164.0	164.0	163.0	139.0												10.0
15.0	127.0	128.0	128.0	127.0	106.0											15.0
20.0	98.0	100.0	94.0	89.0	83.0	77.0	69.0	54.0								20.0
25.0	69.0	72.0	68.0	66.0	61.0	60.0	55.0	51.0	44.0							25.0
30.0	51.0	52.0	53.0	50.0	46.0	46.0	42.4	39.6	37.8	37.6	30.4	25.6				30.0
35.0		39.2	41.2	41.6	36.4	36.8	36.8	31.6	30.2	31.0	29.0	25.6	21.8			35.0
40.0		40.0	33.6	34.0	29.6	32.6	30.4	26.8	27.2	27.2	27.0	24.6	21.8	19.0	17.8	40.0
45.0			27.2	28.0	27.2	27.4	25.4	24.4	24.8	23.0	22.8	22.0	20.0	19.0	17.8	45.0
50.0			22.4	23.2	24.6	23.2	21.6	22.4	21.8	19.4	20.6	19.2	17.8	16.8	16.4	50.0
55.0			18.4	20.2	20.8	20.0	18.4	19.8	18.8	16.6	17.8	16.4	15.2	14.4	13.8	55.0
60.0				17.6	17.6	17.4	16.0	17.2	16.4	14.4	15.4	14.2	13.2	12.2	11.8	60.0
65.0				15.0	15.2	15.6	13.8	15.0	14.2	12.4	13.4	12.4	11.2	10.4	10.0	65.0
70.0				7.8	13.2	14.0	12.8	13.2	12.6	10.6	11.8	10.8	9.8	8.8	8.6	70.0
75.0					11.6	12.2	12.0	11.8	11.0	9.2	10.4	9.2	8.4	7.6	7.2	75.0
80.0					10.2	10.6	10.6	10.2	9.6	8.0	9.0	8.0	7.2	6.4	6.0	80.0
85.0						9.4	9.2	8.8	8.4	6.8	8.0	7.0	6.0	5.4	5.0	85.0
90.0						8.2	8.0	7.8	7.4	5.8	7.0	6.0	5.2	4.4	4.0	90.0
95.0						4.4	7.0	6.8	6.2	5.0	6.0	5.2	4.4	3.6	3.2	95.0
100.0							6.0	5.8	5.4	4.0	5.2	4.4	3.6	2.8	2.6	100.0
105.0							5.2	5.0	4.6	3.2	4.4	3.6	2.8	2.2		105.0
110.0								4.2	3.8	2.6	3.6	3.0	2.2			110.0
115.0								3.6	3.2	1.8	3.0	2.4				115.0
120.0									2.6		2.4					120.0
125.0									2.2		1.8					125.0

THIS CHART IS ONLY A GUIDE AND SHOULD NOT BE USED TO OPERATE THE CRANE.

The individual crane's load chart, operating instructions and other instructional plates must be read and understood prior to operating the crane

Load charts

Main boom



11,3 m - 60,0 m (37 ft - 197 ft)



7,2 m (23.6 ft)



360°



6,7 (14,700 lb)



Pounds x 1000

Feet	37.2	50.8	64.4	77.9	91.3	104.4	117.1	128.4	139.8	151.2	162.5	173.5	184.1	190.4	196.9	Feet
9.0	174.0															9.0
10.0	164.0	164.0	163.0	139.0												10.0
15.0	127.0	128.0	127.0	127.0	106.0											15.0
20.0	96.0	98.0	88.0	83.0	79.0	72.0	69.0	54.0								20.0
25.0	64.0	69.0	63.0	62.0	57.0	56.0	51.0	48.0	44.0							25.0
30.0		48.0	49.0	46.0	42.8	42.8	42.0	36.6	34.8	34.8	30.4	25.6				30.0
35.0		37.0	38.2	36.2	33.6	36.0	34.2	29.4	29.8	30.4	28.2	25.6	21.8			35.0
40.0		28.4	31.2	30.8	29.6	30.2	28.0	26.8	27.2	25.0	25.0	23.2	21.8	19.0	17.8	40.0
45.0			25.0	25.2	26.6	25.2	23.4	24.4	23.4	21.0	22.0	20.6	19.2	18.0	17.6	45.0
50.0			20.4	21.8	22.6	21.4	19.8	21.0	20.0	17.8	18.8	17.4	16.2	15.2	14.8	50.0
55.0			16.8	19.0	19.0	18.4	16.8	18.2	17.2	15.0	16.2	15.0	13.8	12.8	12.4	55.0
60.0				16.0	16.2	17.0	14.4	15.8	14.8	12.8	14.0	12.8	11.8	10.8	10.4	60.0
65.0				13.6	13.8	14.8	12.4	13.8	13.0	11.0	12.2	11.0	10.0	9.2	8.8	65.0
70.0				7.6	12.2	12.8	10.6	12.0	11.2	9.4	10.6	9.4	8.6	7.6	7.4	70.0
75.0					10.4	11.0	9.0	10.6	9.8	8.0	9.2	8.2	7.2	6.4	6.2	75.0
80.0					9.0	9.6	7.6	9.2	8.6	6.8	8.0	7.0	6.0	5.4	5.0	80.0
85.0						8.2	6.4	7.8	7.4	5.8	6.8	6.0	5.0	4.4	4.0	85.0
90.0						7.2	5.2	6.8	6.4	4.8	6.0	5.0	4.2	3.4	3.2	90.0
95.0						3.4	4.4	5.8	5.4	4.0	5.2	4.2	3.4	2.6	2.4	95.0
100.0							3.4	5.0	4.6	3.2	4.4	3.6	2.8	2.0		100.0
105.0							2.8	4.2	3.8	2.4	3.6	2.8	2.0			105.0
110.0								3.6	3.0		3.0	2.2				110.0
115.0								3.0	2.4		2.2					115.0
120.0									2.0							120.0



11,3 m - 60,0 m (37 ft - 197 ft)



7,2 m (23.6 ft)



360°



5,7 t (12,500 lb)



Pounds x 1000

Feet	37.2	50.8	64.4	77.9	91.3	104.4	117.1	128.4	139.8	151.2	162.5	173.5	184.1	190.4	196.9	Feet
9.0	173.0															9.0
10.0	163.0	164.0	162.0	139.0												10.0
15.0	127.0	127.0	127.0	126.0	106.0											15.0
20.0	94.0	96.0	88.0	80.0	76.0	70.0	67.0	54.0								20.0
25.0	62.0	66.0	63.0	59.0	55.0	54.0	49.0	46.0	43.4							25.0
30.0		46.0	47.0	47.0	41.0	41.0	40.8	34.8	33.2	33.2	30.4	25.6				30.0
35.0		35.4	37.8	37.0	33.0	35.2	32.8	29.4	29.8	29.0	28.2	25.2	21.8			35.0
40.0		27.0	29.8	30.0	29.6	28.8	26.8	26.8	26.6	24.0	24.2	22.2	20.6	19.0	17.8	40.0
45.0			23.8	24.6	25.4	24.0	22.2	23.6	22.4	20.0	21.0	19.6	18.2	17.0	16.6	45.0
50.0			19.6	21.2	21.6	20.4	18.8	20.0	19.0	16.8	17.8	16.6	15.2	14.4	13.8	50.0
55.0			15.8	18.0	18.2	18.4	16.4	17.2	16.4	14.2	15.4	14.2	13.0	12.0	11.6	55.0
60.0				15.2	15.4	16.2	15.0	15.0	14.0	12.2	13.2	12.0	11.0	10.0	9.8	60.0
65.0				12.8	13.4	14.0	13.6	13.0	12.2	10.2	11.4	10.4	9.4	8.4	8.2	65.0
70.0				7.6	11.4	12.0	11.8	11.4	10.6	8.8	9.8	8.8	7.8	7.0	6.8	70.0
75.0					9.8	10.4	10.2	9.8	9.2	7.4	8.6	7.6	6.6	5.8	5.6	75.0
80.0					8.4	9.0	8.8	8.6	8.0	6.2	7.4	6.4	5.6	4.8	4.4	80.0
85.0						7.8	7.6	7.4	6.8	5.2	6.4	5.4	4.6	3.8	3.6	85.0
90.0						6.6	6.6	6.2	5.8	4.4	5.4	4.6	3.8	3.0	2.6	90.0
95.0						3.0	5.6	5.4	4.8	3.6	4.6	3.8	3.0	2.2	2.0	95.0
100.0							4.8	4.4	4.0	2.8	4.0	3.0	2.2			100.0
105.0							4.0	3.8	3.4	2.0	3.2	2.4				105.0
110.0								3.0	2.6		2.6					110.0
115.0								2.6	2.0		1.8					115.0

THIS CHART IS ONLY A GUIDE AND SHOULD NOT BE USED TO OPERATE THE CRANE.

The individual crane's load chart, operating instructions and other instructional plates must be read and understood prior to operating the crane

Load charts

Main boom



11,3 m - 60,0 m (37 ft - 197 ft)



7,2 m (23.6 ft)



360°



4,5 t (9900 lb)



Pounds x 1000

Feet	37.2	50.8	64.4	77.9	91.3	104.4	117.1	128.4	139.8	151.2	162.5	173.5	184.1	190.4	196.9	Feet
9.0	173.0															9.0
10.0	163.0	164.0	162.0	139.0												10.0
15.0	127.0	127.0	127.0	120.0	106.0											15.0
20.0	92.0	91.0	83.0	76.0	72.0	70.0	63.0	54.0								20.0
25.0	58.0	63.0	60.0	56.0	52.0	51.0	46.0	43.0	40.8							25.0
30.0	42.2	43.8	44.0	44.0	38.6	39.6	38.6	32.8	32.6	32.6	29.6	25.6				30.0
35.0		33.2	36.0	35.0	33.0	33.2	30.8	29.4	29.8	27.4	27.0	24.6	21.8			35.0
40.0		25.4	28.0	28.2	28.8	27.2	25.2	26.4	25.0	22.4	23.4	21.8	20.2	19.0	17.8	40.0
45.0			22.4	23.8	24.0	22.6	20.8	22.2	21.0	18.6	19.6	18.2	16.8	15.8	15.4	45.0
50.0			18.2	20.2	20.2	20.0	18.0	18.8	17.8	15.6	16.6	15.4	14.2	13.2	12.8	50.0
55.0			14.6	16.8	17.2	17.4	16.4	16.0	15.2	13.2	14.2	13.0	11.8	11.0	10.6	55.0
60.0				14.0	14.6	15.2	14.4	13.8	13.0	11.0	12.2	11.0	10.0	9.2	8.8	60.0
65.0				11.8	12.4	13.0	12.6	12.0	11.2	9.4	10.4	9.4	8.4	7.6	7.2	65.0
70.0				7.2	10.6	11.2	11.0	10.4	9.6	7.8	9.0	8.0	7.0	6.2	5.8	70.0
75.0					9.0	9.6	9.4	9.0	8.4	6.6	7.8	6.8	5.8	5.0	4.8	75.0
80.0					7.6	8.2	8.0	7.8	7.2	5.6	6.6	5.6	4.8	4.0	3.8	80.0
85.0						7.0	6.8	6.6	6.2	4.6	5.6	4.8	3.8	3.0	2.8	85.0
90.0						6.0	5.8	5.6	5.2	3.6	4.8	3.8	3.0	2.2	2.0	90.0
95.0						2.2	5.0	4.6	4.2	2.8	4.0	3.2	2.4			95.0
100.0							4.2	3.8	3.4	2.2	3.2	2.4				100.0
105.0							3.4	3.2	2.8		2.6					105.0
110.0								2.6	2.2		2.0					110.0
115.0								2.0								115.0



11,3 m - 60,0 m (37 ft - 197 ft)



7,2 m (23.6 ft)



360°



0,8 t (1700 lb)



Pounds x 1000

Feet	37.2	50.8	64.4	77.9	91.3	104.4	117.1	128.4	139.8	151.2	162.5	173.5	184.1	190.4	196.9	Feet
9.0	173.0															9.0
10.0	163.0	163.0	162.0	139.0												10.0
15.0	123.0	124.0	118.0	107.0	95.0											15.0
20.0	78.0	78.0	73.0	67.0	61.0	59.0	53.0	49.0								20.0
25.0	48.0	52.0	50.0	50.0	42.6	44.0	41.8	36.0	33.4							25.0
30.0		36.8	38.2	36.8	36.6	34.6	31.8	32.6	31.2	27.8	27.4	24.6				30.0
35.0		26.8	29.6	29.0	29.2	27.4	25.2	26.4	25.0	22.2	23.2	21.4	19.8			35.0
40.0		20.0	22.8	24.4	23.6	23.6	22.0	21.6	20.4	17.8	19.0	17.4	16.0	14.8	14.4	40.0
45.0			18.0	20.0	19.8	19.6	18.6	17.8	16.8	14.6	15.6	14.4	13.0	12.0	11.6	45.0
50.0			14.2	16.2	16.6	16.4	15.6	15.0	14.0	12.0	13.0	11.8	10.6	9.8	9.4	50.0
55.0			11.2	13.2	13.8	14.0	13.2	12.6	11.8	9.8	11.0	9.8	8.8	7.8	7.4	55.0
60.0				10.8	11.4	11.8	11.2	10.8	10.0	8.0	9.2	8.2	7.2	6.2	6.0	60.0
65.0					9.0	9.6	10.0	9.6	9.0	6.6	7.8	6.6	5.8	4.8	4.6	65.0
70.0					4.4	8.0	8.4	8.2	7.8	7.0	5.2	6.4	5.4	4.6	3.8	70.0
75.0						6.6	7.0	7.0	6.6	5.8	4.2	5.4	4.4	3.6	2.8	75.0
80.0						5.4	5.8	5.8	5.4	4.8	3.2	4.4	3.4	2.6	2.4	80.0
85.0							4.8	4.8	4.4	4.0	2.4	3.6	2.6			85.0
90.0							4.0	3.8	3.6	3.2		2.8	1.8			90.0
95.0								3.0	2.8	2.4		2.0				95.0
100.0								2.4	2.0							100.0

THIS CHART IS ONLY A GUIDE AND SHOULD NOT BE USED TO OPERATE THE CRANE.

The individual crane's load chart, operating instructions and other instructional plates must be read and understood prior to operating the crane

Load charts

Main boom and telescopic swingaway



11,3 m - 60,0 m
(37 ft - 196.9 ft)



0°-45°
11,1 m (36.4 ft)



7,2 m
(23.6 ft)



360°



26,2 t
(57,700 lb)



Pounds x 1000

ft	37.2 36.4			117.1 36.4			184.1 36.4			196.9 36.4			ft
	0°	0°-20°	20°-45°	0°	0°-20°	20°-45°	0°	0°-20°	20°-45°	0°	0°-20°	20°-45°	
10.0	31.4												10.0
15.0	28.6												15.0
20.0	24.2	16.6		22.6									20.0
25.0	20.6	14.6		22.0									25.0
30.0	17.8	13.4	10.4	21.4									30.0
35.0	15.4	12.2	10.0	21.0	15.8								35.0
40.0	13.6	11.4	9.6	20.4	14.8		9.6			7.6			40.0
45.0	12.4	10.6	9.2	20.0	14.2	10.2	9.6			7.6			45.0
50.0	11.2	10.0	9.0	19.6	13.6	10.0	9.6	9.6		7.6			50.0
55.0	10.2	9.4	9.0	19.0	13.0	9.8	9.6	9.6		7.6	7.6		55.0
60.0	9.4	9.0		17.8	12.4	9.6	9.6	9.6		7.6	7.6		60.0
65.0	8.8	8.6		16.8	12.0	9.6	9.6	9.6		7.6	7.6		65.0
70.0				15.6	11.6	9.4	9.6	9.6	8.0	7.6	7.6	7.0	70.0
75.0				14.6	11.2	9.2	9.6	9.6	8.0	7.6	7.6	7.0	75.0
80.0				13.8	10.8	9.2	9.6	9.6	8.0	7.6	7.6	7.0	80.0
85.0				13.2	10.6	9.0	9.6	9.6	8.0	7.6	7.6	7.0	85.0
90.0				12.6	10.4	9.0	9.6	9.6	8.0	7.6	7.6	7.0	90.0
95.0				12.0	10.0	9.0	9.6	9.4	8.0	7.6	7.6	7.0	95.0
100.0				10.8	9.8	9.0	8.8	8.8	8.0	7.6	7.6	7.0	100.0
105.0				9.6	9.6	9.0	7.6	7.6	8.0	7.4	7.4	7.0	105.0
110.0				8.4	8.4	9.0	6.8	6.8	7.6	6.4	6.4	7.0	110.0
115.0				7.4	7.4	8.0	6.0	6.0	6.8	5.6	5.6	6.4	115.0
120.0				6.4	6.4		5.2	5.2	5.8	4.8	4.8	5.6	120.0
125.0				5.6	5.6		4.4	4.4	5.2	4.2	4.2	4.8	125.0
130.0				4.8	4.8		3.8	3.8	4.4	3.4	3.4	4.2	130.0
135.0				4.2	4.2		3.2	3.2	3.8	2.8	2.8	3.6	135.0
140.0				3.6	3.6		2.6	2.6	3.2	2.4	2.4	3.0	140.0
145.0				3.0	3.0		2.0	2.0	2.6	1.8	1.8	2.4	145.0
150.0									2.0			1.8	150.0

THIS CHART IS ONLY A GUIDE AND SHOULD NOT BE USED TO OPERATE THE CRANE.

The individual crane's load chart, operating instructions and other instructional plates must be read and understood prior to operating the crane

Load charts

Main boom and telescopic swingaway



11,3 m - 60,0 m
(37 ft - 196.9 ft)



0°-45°
17,6 m (57.8 ft)



7,2 m
(23.6 ft)



360°



26,2 t
(57,700 lb)



Pounds x 1000

ft	37.2 57.8			117.1 57.8			184.1 57.8			196.9 57.8			ft
	0°	0°-20°	20°-45°	0°	0°-20°	20°-45°	0°	0°-20°	20°-45°	0°	0°-20°	20°-45°	
10.0	15.6												10.0
15.0	15.6												15.0
20.0	15.4												20.0
25.0	14.6												25.0
30.0	13.2	9.6		12.6									30.0
35.0	11.6	8.8		12.4									35.0
40.0	10.4	8.0		12.0									40.0
45.0	9.4	7.4		11.8			6.8						45.0
50.0	8.6	7.0	5.8	11.6	8.6		6.8			5.8			50.0
55.0	7.8	6.6	5.4	11.4	8.2		6.8			5.8			55.0
60.0	7.2	6.2	5.2	11.2	7.8		6.8			5.8			60.0
65.0	6.6	5.8	5.2	10.8	7.6		6.8			5.8			65.0
70.0	6.2	5.6	5.0	10.2	7.2	5.6	6.8	6.8		5.8			70.0
75.0	5.8	5.2	5.0	9.8	7.0	5.4	6.8	6.8		5.8	5.8		75.0
80.0	5.4	5.0		9.2	6.8	5.4	6.8	6.8		5.8	5.8		80.0
85.0	5.2	5.0		8.8	6.6	5.2	6.8	6.8		5.8	5.8		85.0
90.0				8.4	6.4	5.2	6.8	6.8	5.4	5.8	5.8		90.0
95.0				8.0	6.2	5.2	6.8	6.6	5.2	5.8	5.8	5.2	95.0
100.0				7.6	6.0	5.0	6.8	6.4	5.2	5.8	5.8	5.2	100.0
105.0				7.2	5.8	5.0	6.8	6.2	5.2	5.8	5.8	5.2	105.0
110.0				7.0	5.8	5.0	6.8	6.2	5.0	5.8	5.8	5.0	110.0
115.0				6.8	5.6	5.0	6.8	6.0	5.0	5.8	5.8	5.0	115.0
120.0				6.4	5.4	5.0	6.4	5.8	5.0	5.8	5.8	5.0	120.0
125.0				6.2	5.4	5.0	5.6	5.6	5.0	5.4	5.4	5.0	125.0
130.0				6.0	5.2	5.0	5.0	5.0	5.0	4.8	4.8	5.0	130.0
135.0				5.8	5.2	5.0	4.4	4.4	5.0	4.2	4.2	5.0	135.0
140.0				5.2	5.0		3.8	3.8	4.8	3.6	3.6	4.6	140.0
145.0				4.6	4.6		3.4	3.4	4.2	3.0	3.0	4.0	145.0
150.0				4.0	4.0		2.8	2.8	3.8	2.6	2.6	3.4	150.0
155.0				3.6	3.6		2.4	2.4	3.2	2.0	2.0	3.0	155.0
160.0				3.0	3.0		1.8	1.8	2.8	1.6	1.6	2.4	160.0
165.0				2.6	2.6				2.2			2.0	165.0
170.0									1.8			1.6	170.0

THIS CHART IS ONLY A GUIDE AND SHOULD NOT BE USED TO OPERATE THE CRANE.

The individual crane's load chart, operating instructions and other instructional plates must be read and understood prior to operating the crane

Load charts

Main boom and telescopic swingaway



11,3 m - 60,0 m
(37 ft - 196.9 ft)



0°-45°
25,6 m (84 ft)



7,2 m
(23.6 ft)



360°



26,2 t
(57,700 lb)



Pounds x 1000

ft	37.2			117.1			184.1			196.9			ft
	0°	0°-20°	20°-45°	0°	0°-20°	20°-45°	0°	0°-20°	20°-45°	0°	0°-20°	20°-45°	
20.0	10.2												20.0
25.0	9.6												25.0
30.0	8.8												30.0
35.0	8.2			8.8									35.0
40.0	7.2	7.2		8.6									40.0
45.0	6.4	6.4		8.4									45.0
50.0	5.8	5.8	5.0	8.2			4.4						50.0
55.0	5.0	5.0	4.6	8.0			4.4			3.6			55.0
60.0	4.6	4.6	4.4	7.8	7.0		4.4			3.6			60.0
65.0	4.2	4.2	4.0	7.6	6.6		4.4			3.6			65.0
70.0	3.8	3.8	3.6	7.4	6.2		4.4			3.6			70.0
75.0	3.4	3.4	3.4	7.2	6.0	4.4	4.4	4.4		3.6			75.0
80.0	3.2	3.2	3.2	6.8	5.6	4.2	4.4	4.4		3.6	3.6		80.0
85.0	2.8	2.8	3.0	6.4	5.4	4.0	4.4	4.2		3.6	3.6		85.0
90.0	2.6	2.6	2.8	6.0	5.2	3.8	4.4	4.2		3.6	3.6		90.0
95.0	2.4	2.4	2.6	5.8	4.8	3.6	4.4	4.2	2.8	3.6	3.6	2.6	95.0
100.0	2.2	2.2		5.4	4.6	3.6	4.4	4.2	2.8	3.6	3.6	2.6	100.0
105.0	2.0	2.0		5.2	4.4	3.4	4.2	4.2	2.8	3.6	3.6	2.6	105.0
110.0	1.8	1.8		4.8	4.2	3.2	4.2	4.2	2.8	3.6	3.6	2.6	110.0
115.0	1.8	1.8		4.6	4.0	3.2	4.2	4.2	2.8	3.6	3.6	2.4	115.0
120.0				4.4	4.0	3.0	4.2	4.2	2.8	3.6	3.6	2.4	120.0
125.0				4.2	3.8	3.0	4.2	4.2	2.8	3.6	3.6	2.4	125.0
130.0				4.0	3.6	2.8	4.2	4.0	2.8	3.6	3.6	2.4	130.0
135.0				3.8	3.4	2.8	4.2	4.0	2.8	3.6	3.6	2.4	135.0
140.0				3.6	3.4	2.6	3.6	3.6	2.8	3.2	3.2	2.4	140.0
145.0				3.4	3.2	2.6	3.0	3.0	2.8	2.8	2.8	2.4	145.0
150.0				3.4	3.2	2.4	2.6	2.6	2.8	2.2	2.2	2.4	150.0
155.0				3.2	3.0	2.4	2.2	2.2	2.8	1.8	1.8	2.4	155.0
160.0				3.0	3.0		1.6	1.6	2.6			2.2	160.0
165.0				2.8	2.8				2.0			1.8	165.0
170.0				2.4	2.4				1.6				170.0
175.0				2.0	2.0								175.0
180.0				1.6	1.6								180.0

The lifting capacities correspond to ASME B30.5

The lifting capacities likewise fulfill the requirements of ISO 4305 with regard to stability.

The lifting capacities are given in pounds x 1000.

Lifting capacity = Payload + weight of hook block and suspending device.

The lifting capacities for the main boom only apply with the jib dismantled.

Lifting capacities greater than 154,000 lb require additional equipment.

Lifting capacities greater than 177,000 lb require special equipment.

The right is reserved to modify the load-carrying capacities.

Note: The details in this brochure serve only as general information. The determinant values for the operation of the crane are the lifting capacity tables belonging to it and the operating instructions.

Lifting capacities are indicated by boom length for different levels of extension. The actual boom length will be in accordance with the selected configuration for boom extension.

THIS CHART IS ONLY A GUIDE AND SHOULD NOT BE USED TO OPERATE THE CRANE.

The individual crane's load chart, operating instructions and other instructional plates must be read and understood prior to operating the crane

Specifications

Superstructure



Boom

11,3 m to 60,0 m (37.2 ft to 196.9 ft) seven section TWIN-LOCK™ boom. Maximum tip height 63,0 m (206 ft).



Boom elevation

1 cylinder with safety valve, boom angle from -1.5° to +82°.



Load moment and independent anti-two block system

Load moment and independent anti-two block system with audio visual warning and control lever lock-out. These systems provide graphic display of boom angle, length, radius, tip height, relative load moment, maximum permissible load, load indication and warning of impending two-block condition with lock-out hoist function.



Cab

Aluminium, full vision, tiltable (approx. 20°), safety glass, adjustable operator's seat with suspension (optional), engine-independent heater. Armrest integrated crane controls. Ergonomically arranged instrumentation and crane operating controls.



Slewing

2 slewing gears with axial piston motors, planetary gears, automatic break.



Counterweight

26,2 t (57,700 lbs), consisting of various sections (21,4 t [47,100 lb]) within 2,55 m (8.4 ft) vehicle width). Hydraulic removal system.



Hydraulic system

2 separate circuits, 1 axial piston variable displacement pump with electronic power limiting control and 1 axial piston variable displacement pump for slewing.

Thermostatically controlled oil cooler. Tank capacity: 550 l (145 gallons).



Control system

Full electronic control of all crane movements using electrical control levers with automatic reset to zero. Integrated with the RCL and engine management system by CAN-BUS. Crane Control System (CCS) with system with graphic display. Crane Star telematics system.



Hoist

Axial piston motor with planetary gear and brake. Drum rotation indicator. IR - Hoist camera with light.

* Optional equipment

- Telescopic swingaway 11,1/17,6/25,6 m (36.4/57.8/84 ft) - with hydraulic offset and luffing under load (0° - 45°), controlled from the crane cab
- Auxiliary hoist (in lieu of compensation counterweight)
- Auxiliary boom nose using two parts of line
- Air-conditioning system
- 2.0 m (6.6 ft) side stowed stub jib using 4 parts of line. Offset 0° and 40°
- CraneSTAR asset management system

Carrier



Chassis

Special 4-axle chassis, all-welded torsion-resistant box type construction in high strength steel.



Outriggers

4 double hydraulically telescoping beams with vertical cylinders and outrigger pads. Independent horizontal and vertical movement control on each side of the carrier and from the operators cab. Electronic level indicator with automatic levelling system.



Engine

Mercedes Benz OM470LA, diesel, 6 cylinders, water cooled, turbocharged, 320 kW at 1700 rpm (80/1269 EWG fan loose). Max. torque: 2100 Nm at 1300 rpm. Fuel tank: 200 l + 200 l.

Engine emission: Euromot 4 / EPA / CARB Tier 4 final (non road).



Transmission

Mercedes G 280-16 gears forward and 2 reverse. 2-stage transfer case with longitudinal differential lock.



Drive/Steer

8 x 6 x 8.



Axle lines

4 axle lines, axle lines 1, 2, 3 and 4 steered, axle line 1, 3 and 4 driven.



Suspension

MEGATRAK®. All wheels with independent hydropneumatic suspension and hydraulic lockout. Longitudinal and transverse level control with automatic on highway levelling system. Range +170 mm/-126 mm. Active suspension control on outrigger control units.



Tires

8 tires, 385/95 R25 (14.00 R25).



Steering

Dual circuit, hydraulic power assisted steering with emergency steering pump. Axle lines 1, 2 and 4 steer on highway. Separate electronic hydraulic (steer by wire) steering of the 3rd, and 4th axle line for all wheel steering and crabbing.



Brakes

Service brake: pneumatic dual circuit disc brakes acting on all wheels, air dryer. Permanent brake: exhaust brake and constant throttle brake.

Parking brake: pneumatically operated spring-loaded brake acting on axle lines 2, 3 and 4.



Driver's Cab

Two operator designed, safety glass, driver seat with pneumatic suspension, engine-independent diesel air heater incl. 24 h timer. Complete instrumentation and driving controls. Air conditioning. 12 V plug. Two rotating beacons. Fire extinguisher.



Electrical system

Three-phase alternator 28 V/150A, 2 batteries 12 V/180 Ah. Lighting system and signals 24 V.

* Optional equipment

- 8 x 8 x 8
- 8 tires, size 445/95 R25 (16.00 R25) - Vehicle width 2,75 m (9.02 ft).
- 8 tires, size 525/80 R25 (20.5 R25) - Vehicle width 2,88 m (9.5 ft).
- Folding bunk bed in carrier cab.
- Secondary water retarder.
- Reverse camera system.

*Further optional equipment on request.

Symbols glossary



Axles



Counterweight



Main hoist



Outriggers



Axle load



Crane functions



Auxiliary hoist



Radius



Boom



Crane travel



Hookblock / Capacity



Slewing/
Working range



Boom elevation



Drive/Steer



Hydraulic system



Speed



Boom telescoping



Electrical system



Lattice extension



Suspension



Brakes



Engine



Lattice extension
(luffing)



Transmission / Gear



Cab



Free on wheels



Luffing Jib



mp/h
Travel speed



Carrier frame



Gradeability



Low range



Tyres



Hose reel



Swing-Away



Dolly



Storage box +
rigging gear



Weight per axle in kg



Driveline



Brackets

Notes

Manitowoc Cranes

Regional headquarters

Americas

Milwaukee, Wisconsin, USA

Tel: +1 414 760 4600

Shady Grove, Pennsylvania, USA

Tel: +1 717 597 8121

Fax: +1 717 597 4062

Europe and Africa

Dardilly, France - TOWERS

Tel: +33 (0) 4 72 18 20 20

Fax: +33 (0) 4 72 18 20 00

Wilhelmshaven, Germany - MOBILE

Tel: +49 (0) 4421 294 0

Fax: +49 (0) 4421 294 4301

APAC

Shanghai, China

Tel: +86 21 6457 0066

Fax: +86 21 6457 4955

Singapore

Tel: +65 6264 1188

Fax: +65 6862 4040

Middle East and India

Dubai, UAE

Tel: +971 4 8862677

Fax: +971 4 8862678/79



This document is non-contractual. Constant improvement and engineering progress make it necessary that we reserve the right to make specification, equipment, and price changes without notice. Illustrations shown may include optional equipment and accessories and may not include all standard equipment.